

## How to run the RI-CLPM with Mplus

By Ellen Hamaker

March 21, 2018

The random intercept cross-lagged panel model (RI-CLPM) as proposed by Hamaker, Kuiper and Grasman (2015, Psychological Methods) is a model that decomposes each observed score into a between-person part and a within-person part. While the terminology is clearly inspired by the multilevel literature (where there is a within-cluster level and a between-cluster level), the RI-CLPM is estimated in wide-format rather than in long-format. This means that if you have two variables measured at  $T$  time points, you will have a data file with  $2T$  variables representing these bivariate repeated measures. Estimating the model is based on structural equation modeling (SEM).

The RI-CLPM can be represented like this:

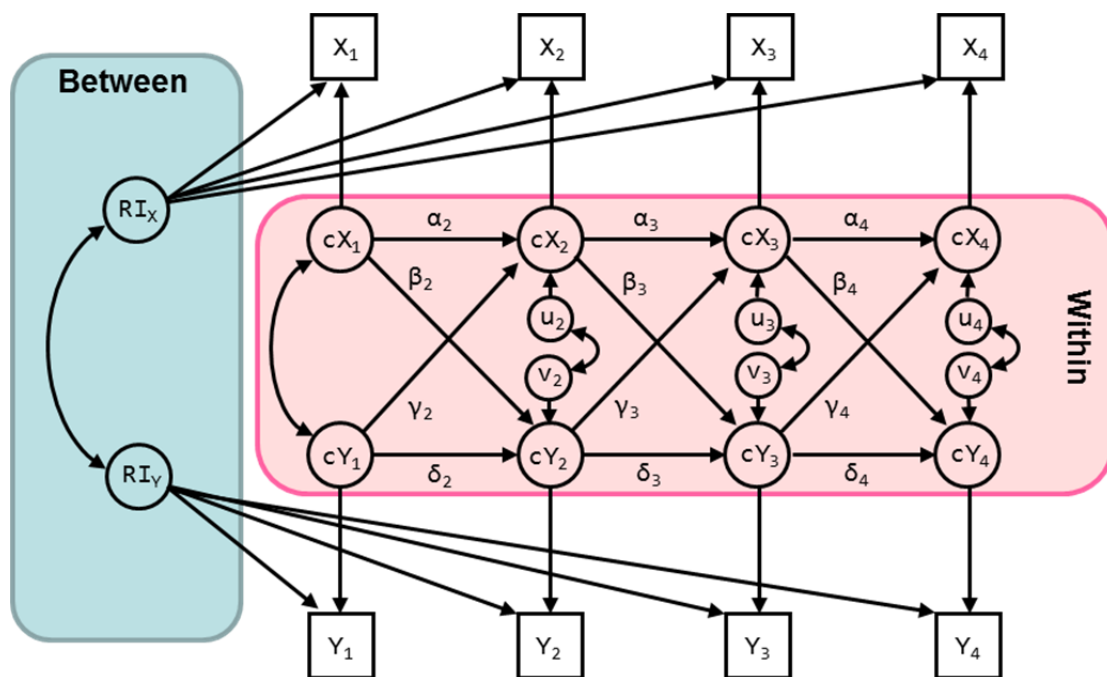

We use this model to simulate data for four time points and 400 cases. For simplicity the lagged parameter values we use are invariant over time (but we will estimate them without this constraint).

These specific values are:

$$\alpha = 0.5$$

$$\beta = 0.0$$

$$\gamma = 0.2$$

$$\delta = 0.4$$

Other parameters are the variances and covariance at the between-person level: variances were set to 2 and the covariance to -1. Furthermore, the within-person residual variances were set to 0.9, and the covariance of these residuals was set to 0.2. The within-person variances at the first wave were set to 1.35 for  $cX_1$  and 1.07 for  $cY_1$ , and a covariance between these terms to 0.36. These parameter values imply it is a stationary process, meaning that the within-person variances and covariance are invariant

over time. Hence, the proportions of explained variance at the within level are  $(1.35-0.9)/1.35=0.33$  for x, and  $(1.07-0.9)/1.07=0.16$  for y. Furthermore, the intraclass correlations are  $2.00/(2.00+1.35)= 0.60$  for x and  $2.00/(2.00+1.07)=0.65$  for y. The grand means were set to 10 and 8 for x and y respectively.

To specify this model in Mplus, we use:

```
TITLE:          Fit the RI-CLPM
DATA:          FILE IS RICLPM.dat;
VARIABLE:     NAMES ARE x1 y1 x2 y2 x3 y3 x4 y4;

MODEL:
  ! Create two individual factors (random intercepts)
  RI_x BY x1@1 x2@1 x3@1 x4@1;
  RI_y BY y1@1 y2@1 y3@1 y4@1;

  ! Create within-person centered variables
  cx1 BY x1@1; cx2 BY x2@1; cx3 BY x3@1; cx4 BY x4@1;
  cy1 BY y1@1; cy2 BY y2@1; cy3 BY y3@1; cy4 BY y4@1;

  ! Constrain the measurement error variances to zero
  x1-y4@0;

  ! Estimate the lagged effects between
  ! the within-person centered variables
  cx2 ON cx1 cy1; cx3 ON cx2 cy2; cx4 ON cx3 cy3;
  cy2 ON cx1 cy1; cy3 ON cx2 cy2; cy4 ON cx3 cy3;

  ! Estimate the covariance between the within-person
  ! centered variables at the first wave
  cx1 WITH cy1;

  ! Estimate the covariances between the residuals of
  ! the within-person centered variables (the innovations)
  cx2 WITH cy2; cx3 WITH cy3; cx4 WITH cy4;

  ! Fix the correlation between the individual factors and the other
  ! exogenous variables to zero (by default these would be estimated)
  RI_x WITH cx1@0 cy1@0;
  RI_y WITH cx1@0 cy1@0;

OUTPUT:      TECH1 STDYX SAMPSTAT;
```

This model leads to a chi-square of 16.178 with 9 df ( $p=0.063$ ).

Next, we consider a model in which we **constrain the variances of the random intercepts and their covariance to zero**; this implies that there are **no stable between-person differences** in the data.

```
MODEL:
! Create two individual factors (random intercepts)
RI_x BY x1@1 x2@1 x3@1 x4@1;
RI_y BY y1@1 y2@1 y3@1 y4@1;

! Create within-person centered variables
cx1 BY x1@1; cx2 BY x2@1; cx3 BY x3@1; cx4 BY x4@1;
cy1 BY y1@1; cy2 BY y2@1; cy3 BY y3@1; cy4 BY y4@1;

! Constrain the measurement error variances to zero
x1-y4@0;

! Estimate the lagged effects between
! the within-person centered variables
cx2 ON cx1 cy1; cx3 ON cx2 cy2; cx4 ON cx3 cy3;
cy2 ON cx1 cy1; cy3 ON cx2 cy2; cy4 ON cx3 cy3;

! Estimate the covariance between the within-person
! centered variables at the first wave
cx1 WITH cy1;

! Estimate the covariances between the residuals of
! the within-person centered variables (the innovations)
cx2 WITH cy2; cx3 WITH cy3; cx4 WITH cy4;

! Fix the correlation between the individual factors and the other
! exogenous variables to zero (by default these would be estimated)
RI_x WITH cx1@0 cy1@0;
RI_y WITH cx1@0 cy1@0;

! Fix the variances and covariance of the random intercepts to zero
RI_x@0;
RI_y@0;
RI_x WITH RI_y@0;
```

This model results in a chi-square of 140.189 with 12 df ( $p < .0001$ ). Note that this model is nested under the RI-CLPM, as we obtained it by fixing three parameters to zero.

This latter model is actually **statistically identical to the traditional CLPM**, which can be represented as:

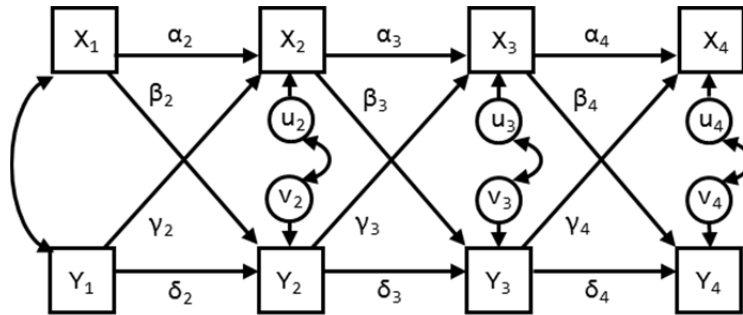

This model can be specified quite simply in Mplus as:

MODEL:

! Estimate the lagged effects between  
! the observed variables  
x2 ON x1 y1; x3 ON x2 y2; x4 ON x3 y3;  
y2 ON x1 y1; y3 ON x2 y2; y4 ON x3 y3;

! Estimate the covariance between the  
! observed variables at the first wave  
x1 WITH y1;

! Estimate the covariances between the  
! residuals of the observed variables  
x2 WITH y2;  
x3 WITH y3;  
x4 WITH y4;

When using this code to estimate the CLPM, we also obtained a chi-square of 140.189 with 12 df ( $p < .0001$ ), which illustrates **these latter two models are statistically equivalent**. Moreover, the lagged parameter estimates they produce are exactly the same, as shown below.

The lagged parameters from the **RI-CLPM in which the variances and covariance of the random intercepts are fixed to zero** are:

CX2	ON				
CX1		0.799	0.031	26.063	0.000
CY1		-0.053	0.031	-1.715	0.086
CX3	ON				
CX2		0.810	0.030	27.185	0.000
CY2		-0.018	0.030	-0.580	0.562
CX4	ON				
CX3		0.779	0.028	27.892	0.000
CY3		-0.045	0.029	-1.563	0.118

CY2	ON				
CX1		-0.171	0.029	-5.854	0.000
CY1		0.767	0.030	25.965	0.000
CY3	ON				
CX2		-0.150	0.028	-5.346	0.000
CY2		0.766	0.029	26.850	0.000
CY4	ON				
CX3		-0.131	0.028	-4.614	0.000
CY3		0.788	0.029	27.012	0.000

The lagged parameters from the **traditional CLPM** are:

X2	ON				
X1		0.799	0.031	26.063	0.000
Y1		-0.053	0.031	-1.714	0.086
X3	ON				
X2		0.810	0.030	27.186	0.000
Y2		-0.018	0.030	-0.580	0.562
X4	ON				
X3		0.779	0.028	27.892	0.000
Y3		-0.045	0.029	-1.563	0.118
Y2	ON				
X1		-0.171	0.029	-5.854	0.000
Y1		0.767	0.030	25.964	0.000
Y3	ON				
X2		-0.150	0.028	-5.346	0.000
Y2		0.766	0.029	26.850	0.000
Y4	ON				
X3		-0.131	0.028	-4.614	0.000
Y3		0.788	0.029	27.012	0.000

This shows that the traditional CLPM and the RI-CLPM in which the variances of the random intercepts are fixed to zero lead to **identical lagged parameters**.

However, these lagged parameter estimates **differ starkly** from the ones obtained with the **RI-CLPM**:

CX2	ON				
CX1		0.482	0.088	5.450	0.000
CY1		0.239	0.087	2.759	0.006
CX3	ON				

CX2		0.548	0.074	7.360	0.000
CY2		0.263	0.099	2.662	0.008
CX4	ON				
CX3		0.526	0.060	8.713	0.000
CY3		0.190	0.077	2.456	0.014
CY2	ON				
CX1		0.087	0.074	1.173	0.241
CY1		0.234	0.099	2.371	0.018
CY3	ON				
CX2		-0.055	0.069	-0.789	0.430
CY2		0.332	0.110	3.018	0.003
CY4	ON				
CX3		0.012	0.066	0.181	0.856
CY3		0.301	0.088	3.408	0.001

The most notable differences between the estimates obtained with the RI-CLPM and the ones obtained with the traditional CLPM are:

- the **autoregressive parameters in the traditional CLPM are higher** than the ones in the RI-CLPM; this results is often observed when comparing these models and stems from the fact that the traditional CLPM confounds trait-like stability and moment-to-moment stability, whereas the RI-CLPM separates these two forms of stability;
- the effect from Y on X is significant and positive in the RI-CLPM, while it is non-significant (and negative) in the traditional CLPM; and
- the effect from X to Y is nonsignificant in the RI-CLPM (it was 0 in the data-generating RI-CLPM), while it is significant and negative in the traditional CLPM.

Note that the latter two differences have major consequences for the substantive interpretation of the model. However, such dramatic differences are not necessarily observed when comparing these two models; it may also be the case that the traditional CLPM and the RI-CLPM lead to very similar (substantive) conclusions. Another noteworthy difference is that the standard errors in the RI-CLPM are larger than the ones in the traditional CLPM. This is typically the case and results from the fact that the RI-CLPM is a more flexible model with more parameters, and as a result there is more uncertainty about parameter estimates. This means larger sample sizes are needed, both in terms of number of cases (N) and number of time points (T); simulation studies need to show which of these is more beneficial in terms of increasing power and efficiency.

Because the models are nested, we can compare them using a chi-square test, although we should adjust this test for the fact that two of the three parameters that are constrained, are constrained at the boundary of the parameter space (i.e., the two variances are constrained to zero). As indicated in Hamaker et al. (2015), the usual chi-square test is conservative, which means that if it is significant, we are certain that the correct test would also be significant.

Furthermore, we can add constraints to the RI-CLPM to make the lagged parameters invariant over time; this is often done in practice, but note that it only makes sense when the intervals between the observations are (more or less) equal over time. In that case we can specify the lagged effects as

```
! Constraining the lagged effects between
! the within-person centered variables
cx2 ON cx1 cy1 (a g);
cx3 ON cx2 cy2 (a g);
cx4 ON cx3 cy3 (a g);
cy2 ON cx1 cy1 (b d);
cy3 ON cx2 cy2 (b d);
cy4 ON cx3 cy3 (b d);
```

This results in

CX2	ON				
CX1		0.500	0.055	9.031	0.000
CY1		0.244	0.051	4.800	0.000
CX3	ON				
CX2		0.500	0.055	9.031	0.000
CY2		0.244	0.051	4.800	0.000
CX4	ON				
CX3		0.500	0.055	9.031	0.000
CY3		0.244	0.051	4.800	0.000
CY2	ON				
CX1		0.020	0.045	0.441	0.659
CY1		0.278	0.054	5.155	0.000
CY3	ON				
CX2		0.020	0.045	0.441	0.659
CY2		0.278	0.054	5.155	0.000
CY4	ON				
CX3		0.020	0.045	0.441	0.659
CY3		0.278	0.054	5.155	0.000

Furthermore, the **grand means** can be **constrained over time**, using

```
! Constrain the grand means over time
[x1 x2 x3 x4] (mx);
[y1 y2 y3 y4] (my);
```

Again, we can do chi-square difference tests to see whether these constraints are tenable.

Data that were used (with columns representing x1, y1, x2 y2 x3 y3 x4 y4; rows representing 400 separate cases):

7.556 8.836 7.237 8.976 7.813 10.573 8.654 9.791  
9.832 6.074 12.033 6.974 13.843 6.675 13.552 6.78  
11.574 5.543 12.21 6.066 13.818 5.607 12.461 3.904  
9.572 5.765 9.913 6.527 9.819 5.389 12.102 7.05  
6.699 11.792 8.008 12.095 8.858 10.958 8.385 11.479  
10.202 7.068 11.745 7.615 11.55 7.764 10.39 6.65  
12.905 6.635 11.714 5.858 12.443 7.33 13.34 4.719  
9.808 7.467 8.74 6.855 7.468 6.406 10.162 7.39  
10.084 5.412 9.812 5.964 8.625 5.267 8.519 6.744  
14.275 7.618 14.877 7.326 16.421 6.721 14.217 7.913  
11.509 7.906 11.375 6.923 9.139 5.764 8.821 7.508  
10.13 5.101 10.383 5.624 8.128 3.421 8.869 4.957  
11.571 6.774 12.731 5.784 11.737 3.953 9.78 4.553  
11.362 7.32 11.18 7.379 7.747 6.044 10.846 6.971  
10.271 9.462 9.797 8.513 9.025 10.731 9.755 9.987  
10.9 7.941 10.187 7.31 10.43 7.235 9.025 6.642  
9.928 8.421 9.55 9.777 9.393 9.998 9.988 9.161  
10.519 11.779 11.605 10.345 10.696 10.892 9.438 9.804  
7.707 8.072 8.15 6.945 9.852 8.658 10.089 8.924  
9.638 7.312 11.258 8.58 10.531 7.583 10.719 8.345  
11.337 8.74 10.864 9.438 13.238 8.878 10.952 8.489  
8.65 5.346 9.428 4.979 7.194 5.67 8.2 5.74  
13.872 3.204 11.283 4.258 11.463 5.005 13.341 4.759  
8.308 7.157 9.577 7.833 10.259 7.3 8.41 7.73  
9.1 6.864 8.896 6.506 8.22 9.632 8.93 9.056  
11.313 5.598 9.911 5.224 9.536 5.766 8.739 5.017  
9.028 7.546 10.639 9.835 10.778 8.807 11.027 7.899  
10.945 7.569 10.908 5.976 12.26 6.16 11.375 5.256  
9.127 8.641 6.051 8.112 7.959 10.2 9.022 10.184  
9.373 9.791 8.917 11.981 8.119 12.121 7.794 9.85  
10.526 5.525 11.792 6.426 11.885 7.16 11.372 7.518  
9.416 8.559 8.226 9.659 7.917 10.168 8.953 9.488  
8.87 7.485 10.4 7.023 10.386 8.718 10.226 7.471  
11.833 6.374 13.074 7.746 14.066 6.927 14.312 6.543  
13.765 6.903 14.214 6.587 13.174 5.171 13.208 3.848  
11.538 9.644 11.026 7.953 11.379 9.697 10.062 6.837  
10.405 8.575 9.842 6.834 9.611 6.433 10.7 7.408  
11.309 5.546 9.706 7.117 11.093 7.02 10.279 7.238  
7.296 11.494 7.578 10.188 9.122 10.5 8.536 9.867  
9.013 9.919 10.245 10.588 9.971 8.997 10.699 8.064  
7.988 8.214 9.057 8.805 9.481 11.233 10.554 9.047  
8.83 9.969 9.352 9.818 8.515 9.857 8.634 10.021  
12.278 10.587 13.705 10.096 12.898 7.726 11.243 7.273  
7.38 6.781 8.549 8.524 7.654 8.121 8.255 9.121  
7.851 10.041 7.203 10.471 7.959 8.98 7.769 9.966  
10.209 9.269 12.199 9.359 11.364 8.377 9.505 7.997  
9.041 8.962 8.204 10.123 8.332 9.45 8.547 8.976  
8.174 10.884 7.188 10.994 6.28 9.48 7.506 11.728  
9.629 9.621 9.242 7.293 10.217 8.198 10.733 7.785  
7.67 11.057 8.086 10.231 8.912 9.318 7.696 8.523  
9.7 4.694 11.04 6.404 13.315 6.089 12.51 6.148



8.037 6.748 9.052 8.058 9.581 7.62 10.873 8.983  
10.171 9.096 11.066 7.935 9.715 6.896 9.044 8.403  
8.242 8.831 8.306 9.095 9.302 9.981 9.82 9.652  
8.278 10.794 7.541 10.734 6.596 9.688 6.784 10.11  
10.461 9.323 10.745 7.202 11.97 7.755 10.98 5.471  
3.788 9.306 5.203 9.213 4.563 9.985 5.672 10.617  
10.534 8.655 11.314 9.338 10.745 7.068 9.351 8.789  
12.825 9.253 12.057 7.693 11.571 8.616 10.597 7.6  
10.328 6.1 10.509 4.684 10.347 5.093 10.974 6.714  
6.485 9.809 6.166 9.898 6.126 10.634 6.257 9.497  
9.217 6.452 8.241 7.93 10.437 9.059 11.024 9.484  
8.075 7.916 8.938 7.93 9.552 8.14 9.176 8.152  
9.268 11.087 8.974 10.026 9.48 12.046 9.849 11.637  
10.043 6.684 8.855 6.931 10.475 7.283 12.239 9.39  
11.07 9.71 10.762 8.406 10.147 9.327 11.029 7.883  
13.079 5.576 13.256 5.22 14.612 6.892 13.881 8.182  
10.177 12.255 9.699 9.752 10.161 9.327 9.782 8.698  
7.403 8.999 8.276 9.387 8.575 9.081 9.088 8.279  
10.197 8.19 11.157 9.577 10.127 8.364 10.251 7.815  
7.393 6.911 8.834 6.428 8.518 7.554 9.255 9.131  
8.74 10.236 9.764 10.137 11.018 8.96 10.735 7.984  
6.781 6.091 8.348 7.212 7.523 8.651 8.001 10.198  
8.992 7.819 11.265 6.083 9.593 6.396 10.78 5.781  
7.131 8.593 6.714 7.35 7.194 9.372 7.315 10.999  
8.498 6.54 9.145 7.492 8.052 6.329 8.599 7.431  
8.31 6.858 9.118 9.998 8.778 10.816 10.315 11.323  
8.95 7.778 8.885 9.542 10.221 8.049 8.07 7.549  
10.189 7.927 11.034 7.5 11.776 7.843 11.882 7.621  
10.992 6.502 12.726 7.877 12.943 7.007 12.091 7.991  
9.111 6.966 7.653 8.864 9.117 6.579 8.938 7.582  
7.266 7.376 7.885 9.919 10.051 8.2 9.868 8.443  
11.546 8.36 10.794 9.05 10.483 8.621 11.128 8.618  
12.299 4.787 13.851 6.938 14.181 7.884 14.098 5.846  
8.623 7.512 10.352 4.435 10.424 5.037 8.853 5.653  
9.092 8.205 9.543 9.08 9.988 7.975 8.626 6.626  
10.965 8.816 11.814 7.573 11.321 8.622 11.056 7.991  
6.304 8.217 7.467 8.468 8.588 8.634 6.533 8.313  
11.445 3.341 10.995 4.687 11.707 4.992 10.911 5.164  
12.857 7.497 13.542 7.332 14.825 7.142 13.779 8.405  
8.922 9.965 6.83 9.907 7.929 9.104 9.087 10.502  
8.92 8.024 10.504 8.173 10.825 7.362 10.111 7.624  
10.507 8.129 9.08 9.098 9.048 8.324 9.319 8.101  
9.328 6.992 9.864 6.811 10.195 8.517 12.154 6.462  
10.997 8.134 9.835 8.207 10.538 7.463 9.768 7.453  
10.559 7.673 10.934 6.241 9.55 7.13 9.88 6.005  
10.648 7.896 10.619 7.596 10.396 6.64 9.871 5.956  
7.754 8.514 6.726 9.514 5.702 9.504 4.228 10.167  
12.512 7.833 11.364 9.027 11.401 9.437 10.328 7.859  
12.892 7.937 12.97 8.447 11.945 7.86 10.049 8.849  
12.653 6.246 9.825 4.914 10.351 7.311 12.221 5.189  
13.382 8.798 12.535 7.653 11.129 7.001 10.974 6.146  
10.301 7.842 10.498 7.506 10.664 7.386 11.195 8.68  
9.137 5.441 8.505 6.251 9.658 5.881 10.887 6.29  
12.378 9.129 13.587 8.049 12.206 7.859 11.173 8.058  
9.181 10.397 8.665 10.501 10.114 8.575 9.236 8.118

12.136 8.191 10.917 8.071 10.878 8.963 9.882 7.532  
14.341 6.617 14.263 5.313 14.596 7.466 14.089 5.422  
11.247 7.074 11.325 7.805 11.767 7.383 10.519 7.326  
11.663 6.019 9.651 7.333 9.91 5.909 9.49 5.934  
10.485 6.963 9.36 7.048 11.268 6.339 8.363 6.612  
11.198 8.034 10.719 6.54 9.186 6.225 10.799 6.563  
8.873 8.001 8.461 8.991 10.539 7.794 10.526 7.702  
11.752 9.302 10.896 8.61 9.565 7.58 9.85 8.633  
7.425 7.715 9.247 8.735 9.106 8.174 9.464 7.233  
11.778 8.294 11.875 7.4 10.456 8.83 9.437 8.924  
9.487 8.795 11.124 7.481 10.989 6.669 9.484 8.212  
7.476 9.772 5.84 10.845 7.781 11.877 8.662 11.657  
9.94 9.155 9.299 8.418 9.067 8.486 8.023 9.747  
9.545 3.933 11.114 4.949 10.351 4.871 9.289 5.219  
9.575 4.205 9.591 5.757 8.697 6.127 8.643 6.749  
7.302 7.44 6.206 7.086 8.432 7.551 8.331 7.808  
13.119 3.39 13.762 3.607 14.142 3.249 14.192 4.838  
9.71 7.219 9.384 8.259 9.15 9.145 8.799 7.273  
10.849 10.243 10.948 9.376 11.955 9.2 10.323 8.922  
10.882 7.084 10.603 5.589 10.455 7.361 10.275 5.613  
9.374 6.784 10.492 5.841 10.214 7.204 11.458 5.492  
10.432 4.437 10.443 4.333 13.277 3.434 11.848 3.776  
11.861 5.614 11.482 6.792 10.375 3.517 10.578 5.711  
8.451 9.881 9.627 9.813 9.298 8.644 9.834 9.147  
11.057 4.607 11.372 5.937 10.21 5.551 11.745 5.454  
9.891 8.589 8.691 7.651 10.13 8.842 11.139 9.174  
9.414 6.731 9.044 4.569 9.553 5.365 9.502 3.913  
10.12 8.46 8.723 6.86 8.194 9.036 8.662 10.475  
11.229 9.219 9.766 9.573 9.457 8.424 8.869 8.878  
9.918 7.174 9.427 8.072 9.821 7.691 11.648 9.159  
10.71 7.671 9.216 9.768 11.509 6.773 11.777 8.186  
8.564 8.598 8.623 8.719 8.698 9.607 8.939 10.465  
10.27 7.901 10.24 7.443 9.76 5.421 8.574 5.876  
11.512 11.538 10.202 10.439 9.388 10.986 10.348 9.284  
12.115 8.255 10.452 8.663 10.101 9.531 10.602 9.114  
10.392 8.94 10.494 6.974 11.202 6.559 10.498 6.256  
11.105 6.606 9.883 6.373 7.511 7.874 8.433 5.945  
10.538 8.377 11.135 9.863 11.133 8.999 10.114 9.126  
10.549 7.69 8.809 7.073 8.977 9.043 11.177 8.523  
11.88 7.077 12.808 8.574 11.544 7.359 11.982 8.924  
11.381 9.731 11.238 8.091 10.445 9.149 10.496 9.778  
5.716 10.165 6.898 9.486 5.93 9.325 7.035 8.79  
9.212 9.594 10.837 9.707 10.588 9.367 10.062 10.964  
12.462 7.088 10.8 7.492 12.556 6.523 13.03 6.412  
9.9 6.488 8.729 7.365 9.63 7.675 9.518 6.652  
7.883 8.316 9.769 6.964 10.619 6.574 10.507 6.918  
8.951 7.332 7.869 6.767 8.236 6.942 7.826 7.542  
11.214 8.102 9.733 8.537 8.581 8.916 7.393 8.314  
10.993 10.644 10.371 10.808 11.318 10.165 13.161 9.938  
10.701 6.809 11.315 8.763 9.915 8.606 8.954 6.143  
12.617 8.634 12.366 8.622 12.702 7.818 11.385 7.33  
13.061 8.608 11.765 7.37 12.381 7.347 13.283 7.873  
10.767 6.906 9.269 6.806 9.428 7.683 10.143 5.911  
11.213 7.785 12.378 8.178 11.696 9.193 12.355 8.244  
9.076 8.484 8.676 7.617 8.882 7.278 9.12 7.641

9.531 8.713 10.172 8.419 9.67 6.964 9.289 7.453  
9.878 8.958 10.331 7.91 9.637 7.843 9.13 9.163  
10.724 10.32 9.869 8.927 10.017 8.896 9.772 9.154  
11.383 9.239 10.446 8.287 10.971 8.392 12.787 8.542  
10.578 9.043 9.158 8.646 9.722 10.23 8.196 8.64  
6.37 12.735 8.014 12.374 8.422 12.294 6.731 11.97  
7.52 6.321 8.633 6.151 7.999 7.185 7.47 7.969  
10.442 8.864 8.483 10.459 10.222 9.345 9.772 10.317  
9.696 5.887 11.568 5.674 11.835 5.142 10.117 5.904  
11.288 5.327 9.766 5.128 10.08 6.217 11.065 6.289  
11.05 8.901 11.761 7.839 12.599 8.187 11.171 8.021  
8.355 12.628 9.289 11.918 9.321 12.632 8.718 11.802  
8.307 8.199 10.382 9.362 11.404 9.331 10.211 8.093  
6.405 5.777 5.14 5.58 5.922 5.96 5.093 7.505  
10.434 6.701 10.059 6.168 9.938 5.888 9.442 6.145  
7.232 10.239 5.847 10.932 6.507 10.109 7.163 10.219  
9.47 6.958 9.41 7.832 8.093 8.483 8.596 7.739  
11.71 8.652 10.771 6.262 10.757 6.728 10.246 6.63  
11.682 8.21 10.565 7.413 10.82 6.092 10.059 6.483  
7.605 8.616 7.392 7.163 8.175 6.878 5.498 6.32  
8.336 10.583 11.184 9.3 9.434 8.378 9.355 8.951  
10.497 8.375 7.527 7.464 9.329 8.354 10.084 7.177  
12.247 7.581 12.325 6.987 13.25 7.165 11.621 5.121  
9.962 9.792 10.063 9.187 10.05 8.255 8.583 9.181  
8.132 11.287 7.753 11.546 6.953 10.078 7.594 9.764  
12.985 4.456 12.278 5.707 12.786 6.947 13.861 5.618  
8.394 7.301 7.793 7.62 7.315 9.34 7.241 7.577  
9.26 5.196 9.924 4.561 7.916 5.077 9.794 5.46  
8.773 8.714 10.378 8.389 10.407 8.26 11.292 9.408  
9.858 7.439 10.148 8.324 9.412 7.995 9.135 6.999  
11.431 10.65 11.942 9.566 13.029 9.761 11.459 9.416  
12.027 10.055 12.33 9.124 12.035 10.061 10.394 9.895  
9.633 6.907 10.093 5.881 9.281 7.291 10.861 6.012  
12.09 6.137 12.889 5.908 11.64 5.526 11.762 4.443  
9.082 8.739 10.254 10.748 7.934 7.768 8.558 7.673  
9.965 7.584 10.46 8.566 10.325 7.407 8.839 9.188  
9.862 11.342 8.903 10.192 8.843 8.227 10.694 9.946  
8.629 8.641 8.768 7.532 7.197 6.094 8.732 7.083  
14.342 4.062 14.442 4.955 12.725 6.022 11.675 6.266  
12.171 8.408 12.371 8.128 11.401 7.399 11.047 8.324  
9.015 8.951 7.92 10.197 9.429 10.498 9.09 11.107  
10.95 8.51 9.977 7.548 10.253 8.14 9.376 7.015  
7.611 6.322 7.248 9.293 7.688 9.774 7.426 8.135  
11.364 8.816 10.906 10.06 11.186 9.193 10.866 8.885  
10.044 5.388 10.883 6.142 10.53 5.809 10.745 6.027  
10.628 7.919 11.005 7.669 12.286 8.148 10.341 7.384  
15.802 8.103 14.735 6.117 14.892 7.378 13.357 6.076  
7.002 10.907 8.926 9.149 7.32 8.502 6.75 8.284  
12.595 9.883 12.637 10.496 11.514 8.617 12.234 8.867  
9.627 5.668 9.703 5.593 10.553 5.475 9.826 5.328  
9.019 8.886 12.579 10.791 13.158 10.254 13.955 10.099  
9.107 8.942 8.674 8.749 8.478 7.533 8.621 6.338  
10.422 7.841 11.602 8.933 14.061 8.851 10.933 9.14  
8.959 8.915 10.475 8.847 9.991 8.946 9.413 9.591  
11.111 11.437 9.717 10.272 7.808 9.426 9.924 8.771

11.493 7.588 10.782 9.799 10.787 10.131 11.112 9.231  
10.557 5.572 10.122 5.182 9.554 6.218 11.296 4.787  
10.968 6.407 7.867 4.826 11.016 7.409 12.899 8.988  
7.588 6.975 8.616 9.04 9.679 8.434 8.226 8.955  
11.467 9.101 11.269 10.436 11.432 9.826 10.897 9.205  
10.918 8.954 10.612 8.992 10.011 8.567 10.406 8.766  
9.619 6.778 8.979 7.004 9.116 6.997 10.163 6.387  
10.039 8.561 10.889 6.207 9.967 7.618 9.689 7.491  
8.641 8.69 9.116 8.682 10.691 9.734 9.917 7.815  
11.094 6.22 9.984 5.486 9.66 6.423 8.984 7.665  
10.74 10.741 12.797 10.798 11.98 11.86 11.203 10.388  
6.134 10.738 7.716 11.372 7.453 9.702 6.549 10.64  
8.699 9.599 9.325 9.191 9.602 10.224 8.691 9.966  
12.357 7.782 11.612 6.69 10.299 7.069 10.58 6.171  
9.538 4.514 11.03 5.793 10.448 6.334 11.347 5.659  
12.551 7.698 10.552 6.968 10.188 7.724 9.146 7.233  
8.657 11.717 6.888 11.353 6.543 9.42 8.597 10.681  
8.675 10.186 7.009 9.868 7.587 10.389 7.882 9.545  
11.412 5.676 12.635 5.666 12.711 4.875 11.846 4.829  
10.941 5.998 10.525 4.975 8.792 5.345 10.336 5.147  
9.781 6.544 8.747 7.758 9.087 7.832 8.389 7.672  
10.834 8.668 10.953 8.436 10.009 9.449 9.625 9.209  
11.437 4.261 12.119 7.152 12.792 5.946 11.88 6.2  
9.147 9.356 10.88 7.787 12.111 7.086 11.045 8.648  
11.561 6.224 11.848 6.196 11.16 5.385 10.934 3.858  
11.906 7.228 10.824 4.809 11.664 5.97 13.512 5.166  
8.362 7.169 8.289 5.439 8.719 6.152 8.836 5.511  
10.967 8.439 11.554 9.948 10.004 7.978 10.266 7.78  
11.977 5.598 11.598 7.427 10.795 6.631 9.56 5.156  
11.896 6.145 12.021 5.722 12.231 6.024 13.035 7.461  
7.48 11.067 8.25 11.092 8.512 10.397 9.449 13.223  
9.68 6.224 7.885 4.934 9.902 7.434 9.398 7.632  
6.766 9.864 8.336 8.691 8.294 9.546 8.18 9.112  
10.069 4.642 11.523 4.382 10.801 5.259 10.663 3.756  
8.278 11.22 9.04 9.097 8.193 8.793 7.714 8.63  
10.308 7.111 9.095 7.964 11.675 7.538 12.582 5.502  
9.107 9.427 8.53 6.831 7.513 6.672 7.326 7.182  
10.904 3.98 11.487 5.028 10.376 5.189 10.287 5.571  
8.329 8.152 8.899 7.971 7.728 7.525 8.528 9.448  
7.854 8.126 6.791 6.554 9.803 9.302 11.129 9.237  
8.539 7.321 7.626 7.428 8.525 6.898 8.191 8.436  
10.323 6.552 10.17 7.159 10.1 6.065 10.976 7.248  
9.37 8.276 10.881 8.207 10.063 9.026 10.309 7.755  
9.51 10.387 9.719 11.967 7.767 10.507 9.18 10.735  
7.33 6.498 7.387 6.343 8.24 7.894 8.23 8.062  
11.607 4.876 12.116 6.088 10.442 7.067 10.049 6.603  
14.096 6.544 11.163 5.868 9.846 4.619 10.591 5.994  
11.47 10.221 9.377 8.982 11.011 8.936 11.412 8.861  
11.43 9.647 10.665 9.534 12.621 7.706 13.159 6.856  
7.063 8.902 6.341 8.879 6.142 9.22 6.82 10.602  
12.776 11.344 13.201 9.222 11.437 8.466 12.376 9.196  
6.349 7.846 7.834 7.55 9.039 7.413 8.575 7.529  
9.335 7.943 7.694 8.958 9.043 7.613 7.595 9.357  
9.278 7.269 8.058 7.626 7.398 7.097 7.441 7.481  
8.921 7.031 6.891 5.348 8.617 6.656 8.785 6.585

8.94 10.731 9.786 11.465 10.074 12.009 9.357 11.013  
10.29 8.827 9.095 8.311 10.468 9.606 8.686 6.826  
9.55 12.082 7.149 12.246 8.116 11.559 8.884 10.938  
12.748 6.932 12.78 6.505 11.331 6.252 11.494 7.282  
11.718 8.208 12.144 8.558 13.199 7.783 13.359 7.865  
8.661 9.883 9.237 9.506 8.568 8.286 9.612 9.78  
8.507 4.826 8.655 5.988 10.606 5.939 10.613 5.847  
10.141 5.116 11.752 3.499 11.37 4.263 11.023 4.159  
7.059 8.62 7.164 9.449 6.3 9.382 6.633 9.531  
8.019 7.205 9.199 7.311 8.52 7.178 9.115 6.661  
8.151 8.78 7.708 8.422 9.607 9.893 9.142 10.143  
11.428 7.933 11.603 7.649 10.842 5.933 9.088 7.946  
9.858 11.366 9.398 11.691 9.576 11.226 10.964 11.682  
11.073 5.443 10.321 4.49 9.98 3.805 9.577 3.844  
7.443 7.992 6.966 7.892 7.286 7.204 7.385 6.525  
9.665 9.116 11.267 10.023 11.288 7.992 9.696 7.267  
11.362 10.084 12.102 8.679 12.986 8.221 11.87 9.651  
12.328 6.961 13.027 8.486 11.257 8.944 10.53 8.802  
14.451 6.474 13.887 4.334 14.611 4.553 16.705 5.49  
10.174 7.412 10.287 7.091 11.498 7.55 11.937 5.94  
8.915 9.611 8.18 10.97 7.132 10.38 9.858 10.643  
8.793 5.417 7.697 6.423 8.114 6.199 8.956 7.409  
13.998 8.918 13.533 7.961 13.308 5.913 12.84 6.567  
11.816 8.895 11.018 7.3 11.572 5.765 8.99 5.358  
8.506 8.211 10.267 8.958 9.968 7.334 8.762 8.305  
8.123 10.212 8.615 9.576 8.7 8.985 9.183 9.175  
9.52 6.462 10.006 4.773 8.849 3.994 9.203 5.506  
10.539 8.615 11.165 8.023 10.092 7.12 9.759 7.76  
10.398 8.613 10.869 10.004 9.954 6.935 9.829 8.184  
9.338 7.077 11.673 8.545 11.081 8.015 11.213 8.36  
9.46 8.301 10.449 7.583 10.962 7.86 11.068 7.625  
14.864 7.229 13.549 5.248 11.224 4.653 12.091 6.43  
8.035 8.827 7.233 7.227 7.494 9.778 7.831 9.834  
8.108 7.701 10.39 6.713 8.798 6.325 10.91 8.781  
9.847 5.442 11.962 5.128 11.521 6.5 11.813 5.862  
8.091 8.993 6.492 8.751 7.332 9.405 7.959 9.833  
9.009 8.646 11.444 10.682 10.587 9.475 8.299 8.244  
8.605 13.304 8.42 14.511 8.531 14.66 8.345 13.036  
10.134 7.7 9.548 8.458 9.91 7.691 10.369 9.127  
12.168 6.908 12.644 5.804 10.524 6.421 11.911 5.943  
12.302 4.353 10.654 5.651 13.225 6.649 12.967 6.954  
12.528 8.104 14.314 5.785 11.884 5.18 13.183 4.797  
10.607 4.404 10.028 6.838 10.643 7.271 11.067 7.187  
9.684 8.057 10.423 8.869 9.821 8.66 9.431 8.363  
9.156 5.072 9.889 6.398 12.29 6.715 11.467 6.303  
9.985 5.854 10.576 7.339 9.628 6.676 8.811 7.355  
8.741 5.674 9.436 5.534 10.226 5.477 11.051 4.374  
8.736 7.847 8.102 8.304 9.186 9.414 11.155 11.171  
10.533 6.61 12.357 5.965 11.764 5.463 11.04 5.126  
10.788 6.591 10.797 8.664 11.841 8.325 12.165 8.277  
7.197 4.286 7.081 2.948 5.443 4.47 7.559 3.516  
11.922 5.573 12.133 6.015 9.611 4.592 9.81 4.927  
8.062 9.397 6.744 11.383 6.182 11.141 7.035 9.022  
11.359 8.258 10.744 7.127 11.034 7.221 10.078 9.553  
6.014 7.779 6.255 9.017 6.02 8.907 8.209 8.721

11.299 9.802 10.212 9.893 10.288 9.484 9.27 9.739  
11.944 7.392 11.045 7.063 10.488 7.973 10.289 8.244  
7.205 7.475 7.729 8.232 10.608 8.419 11.201 8.938  
12.623 7.586 11.239 8.284 10.772 7.733 11.519 8.997  
8.191 5.69 8.451 6.232 9.128 6.793 6.551 7.525  
10.933 6.856 9.628 5.179 8.372 6.414 11.088 6.235  
12.131 6.732 10.727 6.121 10.99 6.981 11.906 5.941  
8.218 7.64 9.031 7.478 9.295 8.466 8.809 9.808  
7.633 11.815 9.006 10.536 7.82 9.898 6.819 9.756  
10.931 5.295 10.56 4.935 9.813 2.548 9.07 5.092  
10.636 5.352 9.947 7.565 11.061 9.123 11.518 7.293  
10.267 9.239 9.697 9.332 10.605 9.872 10.818 8.895  
12.293 7.905 9.643 7.474 11.037 8.323 11.66 9.981  
7.255 5.416 6.945 5.517 6.318 5.375 6.897 8.216  
7.506 7.87 7.37 7.396 8.893 7.044 9.861 8.839  
10.705 8.049 8.729 7.231 8.306 7.147 7.853 5.759  
10.091 8.259 8.115 7.885 8.025 7.973 8.15 6.893  
7.19 12.062 7.154 10.989 8.065 12.205 8.659 11.894  
12.884 8.774 14.032 6.371 12.565 7.531 13.401 7.781  
10.654 9.027 8.195 9.62 8.306 8.873 9.155 9.577  
7.825 9.403 9.481 9.375 10.374 8.455 9.276 9.743  
8.928 8.698 8.541 9.189 9.385 8.172 9.299 8.737  
8.605 7.354 7.357 8.041 7.524 7.444 8.092 8.311  
10.083 6.11 11.291 5.446 11.652 6.163 10.319 5.516  
8.728 8.58 9.14 8.95 9.307 8.67 8.788 7.193  
6.447 7.744 8.049 9.363 7.015 9.81 8.108 9.18  
12.029 8.189 12.736 7.97 12.57 5.508 12.005 7.037  
8.946 5.067 11.615 5.742 12.168 6.231 11.451 7.11  
8.849 8.401 10.943 7.573 9.848 7.482 10.16 7.805  
10.848 7.579 9.823 7.567 9.087 6.425 7.529 6.223  
12.03 8.889 12.835 8.484 12.485 9.36 12.348 7.497  
7.228 6.998 7.573 7.132 8.679 7.499 8.553 8.304  
12.484 9.365 11.817 9.276 12.071 9.95 12.168 10.135  
9.082 7.098 9.577 8.183 11.42 8.99 11.217 8.079  
10.794 9.424 10.993 8.344 9.118 7.156 9.372 8.863  
7.409 5.648 10.702 8.021 10.105 7.262 8.942 6.452  
6.023 8.302 8.24 9.355 8.211 8.655 7.475 8.35  
8.184 7.972 8.198 9.754 11.378 9.494 11.187 8.389  
8.501 10.56 9.211 11.451 7.33 12.821 8.761 11.218  
6.136 8.416 7.095 9.46 6.304 9.692 6.213 9.658  
11.99 7.388 10.534 7.738 10.936 6.564 9.561 7.344  
6.418 7.135 6.564 8.197 6.584 7.363 7.127 8.196  
6.998 13.601 7.37 12.653 7.374 11.948 7.248 13.342  
10.716 7.75 9.987 8.525 9.881 8.076 8.624 6.931  
11.805 9.329 10.841 8.281 9.192 7.702 8.262 7.639  
10.616 9.646 10.702 8.586 10.637 9.13 11.012 8.223  
9.181 6.443 9.959 6.247 9.163 6.455 8.686 6.433  
9.967 6.415 11.145 7.377 11.02 6.606 8.894 6.549  
8.102 7.471 9.998 8.36 10.957 10.565 8.761 9.378  
9.264 6.399 9.321 8.384 8.629 5.933 8.585 9.278  
9.755 9.223 10.253 8.298 10.171 9.685 10.361 11.169  
10.132 8.095 9.849 8.248 9.637 8.652 9.498 9.2  
6.3 7.72 8.63 9.649 10.515 7.936 9.475 9.505  
11.646 7.119 10.016 5.651 9.746 6.292 10.167 6.465  
12.136 6.435 13.269 4.563 12.267 3.825 12.585 4.041

13.113 10.514 12.363 8.543 12.226 7.766 11.341 8.434  
9.779 8.085 9.809 6.902 8.868 6.151 8.641 6.566  
8.558 7.601 8.073 9.583 9.912 8.418 9.893 7.944  
6.768 4.879 6.338 5.615 7.035 6.287 7.881 6.402  
11.015 7.107 11.638 6.388 11.975 7.242 12.835 7.386  
9.256 5.237 11.594 7.483 9.912 5.611 10.423 6.739  
8.326 8.957 10.84 10.008 12.188 8.902 11.604 8.408  
9.557 8.02 9.677 6.538 8.378 7.071 9.39 7.075  
10.513 10.102 11.562 9.325 10.889 7.956 9.895 7.391  
7.249 7.781 5.227 9.776 6.924 10.161 10.197 10.276  
12.207 11.806 11.476 10.609 10.482 9.305 9.949 9.843  
9.348 8.001 10.527 8.55 10.843 7.746 11.52 8.799  
7.699 8.117 7.42 9.159 8.002 8.617 8.035 8.664  
7.613 7.45 8.215 7.918 10.598 10.871 10.242 8.488  
7.528 8.298 6.125 7.209 6.59 8.994 8.7 10.066  
9.253 9.4 9.965 7.602 8.026 7.692 6.423 7.894  
11.043 9.744 10.444 7.842 9.305 7.036 9.691 8.724  
8.924 7.905 8.943 9.1 9.751 8.469 9.629 8.598  
10.799 6.281 10.512 7.167 9.568 6.988 9.766 5.109